

novaX

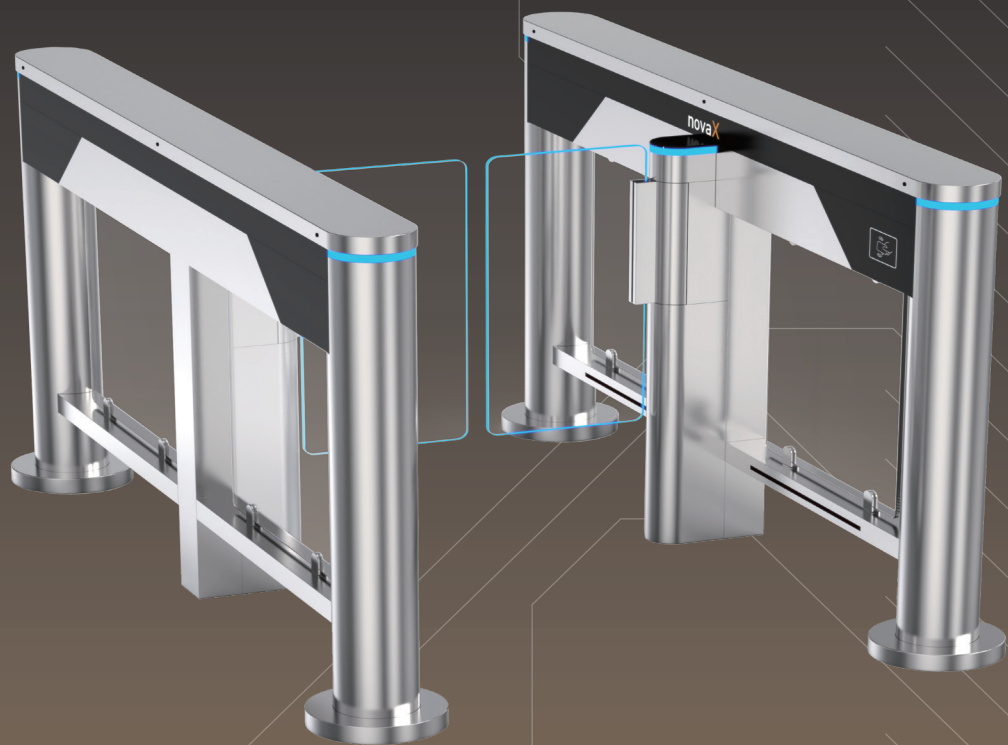

NT-D40 NT Series Swing Speed Gate



International Quality Standards | Lead-edge Technologies | User-friendly Design

MAKE IT SMARTER

PRODUCT INTRODUCTION



NT-D40 speed gate blends modern design with high performance. Featuring a sleek cabinet, black card panel, and LED strips, it supports up to 45 users per minute—ideal for offices, transport hubs, and event venues. Built from brushed stainless steel, it offers customizable passage widths and arm sizes for accessibility and security.

CREDENTIALS

- Remote Control
- Touchless Button
- Card
- QR Code
- Fingerprint
- Facial Recognition
- Palm Vein

FUNCTIONAL FEATURES

- Collision & Security Control: Durable mechanism prevents any unauthorized entry and resists external impact
- Infrared Sensor: Detects any illegal and reverse intrusion
- Single / Two-way Entry: Allow entry from one or both directions
- LED Indicator: Blue light: power on; Green light: access granted; Red light: access denied
- Access Control System Integration
- Easy Installation & Maintenance
- Quiet and Smooth Operation
- Alarm Alerts for Unauthorized Access
- Automatic Arm Reset: Arms return to their default position, regardless of interruption

BASIC SPECIFICATIONS

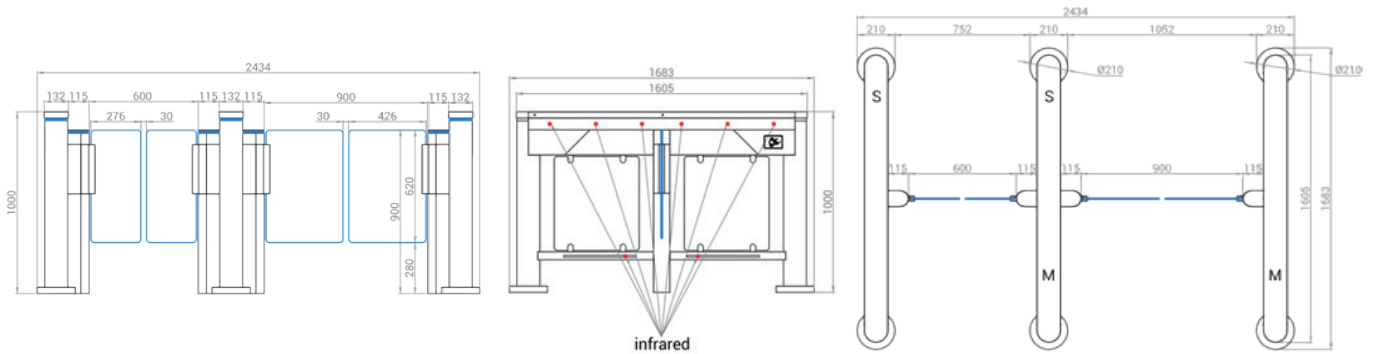

SPECIFICATIONS

	NT-D40
Housing Material	304 Stainless Steel+ Tempered Glass
Arm Material	Plexiglass 10mm Tempered glass 8mm/10mm (optional)
Dimensions	Standard 1683 mm (L) × 132 mm (W) × 1000 mm (H)
Infrared Sensor	Standard 8 pairs
Intended Use	Indoor/ outdoor (upgradable)
Communication	Dry contact, Relay signal, RS485
IP Level	IP54 (standard), IP65 (upgradable)



KEY TECHNICAL METRICS

■ Throughput:	45 people/minute (short arm); 25 people/minute (tall arm)	■ MCBF:	15 million
■ Door Opening:	90° to the middle	■ Power Drive:	DC 24V
■ Movement Angle:	180°	■ Supply Voltage:	AC110V ± 10% 60Hz, AC220V ± 10% 50Hz
■ Lifespan:	≥15M times	■ Power Consumption:	40W
■ Operating Speed:	0.1s – 1.2s	■ Operating Temperature:	-20 °C to 75 °C
■ Safety Mechanism:	Gate open automatically upon power failure	■ Operating Humidity:	0 – 95% in non-condensing state

CUSTOMIZABLE OPTIONS

Appearance:	Customizable body colors
Passage Width:	600mm (standard), 1200mm max. (Optional)
Arm Glass:	900mm (standard), 1800mm max. (optional); hollow glass available for extreme size
Card Reader Size:	Customizable up to 100 mm (L) × 50 mm (W) × 25 mm (T)
Infrared Sensor:	Standard 8 pairs and number expandable
Turnstile Base:	Optional configuration available
Operating Speed:	Customizable to meet site requirements